

A B C D E F G H I J K L M N O P R

1
2
3
4
5
6
7
8
9
10

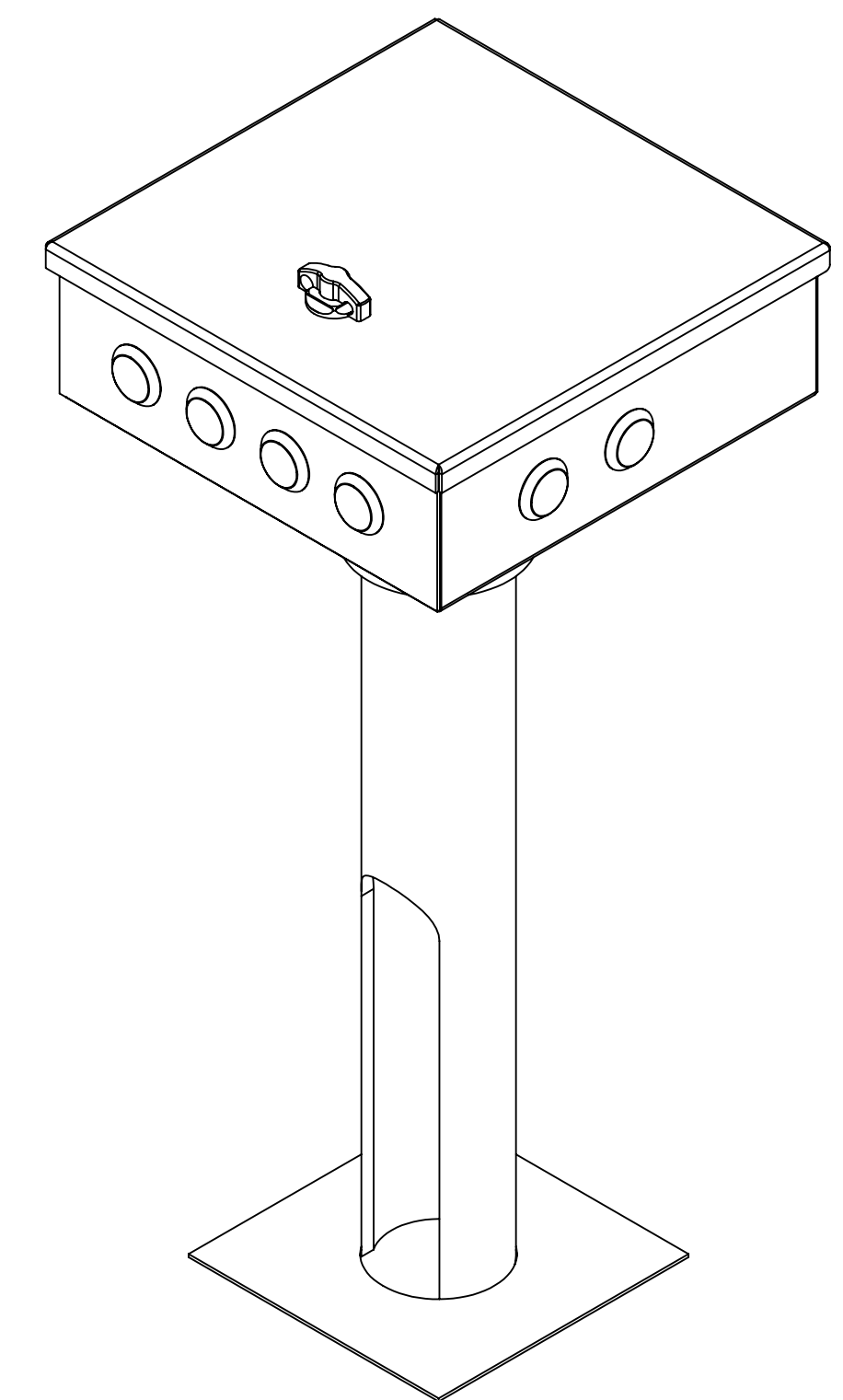
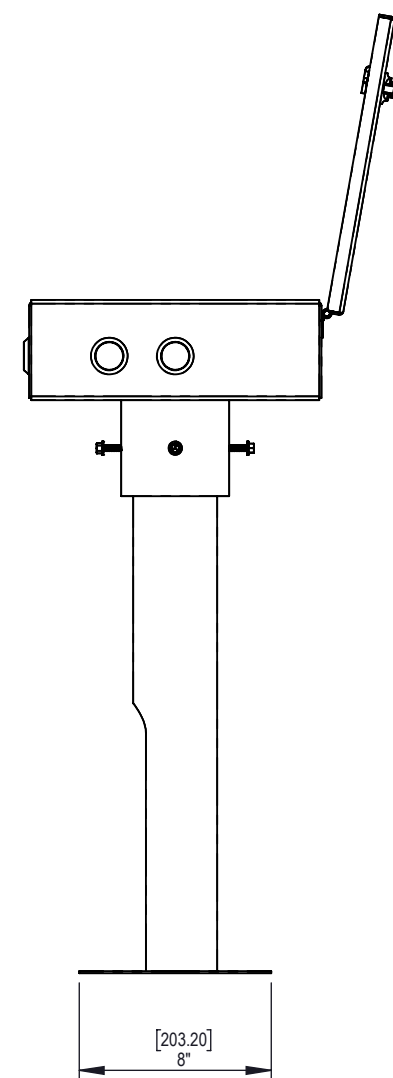
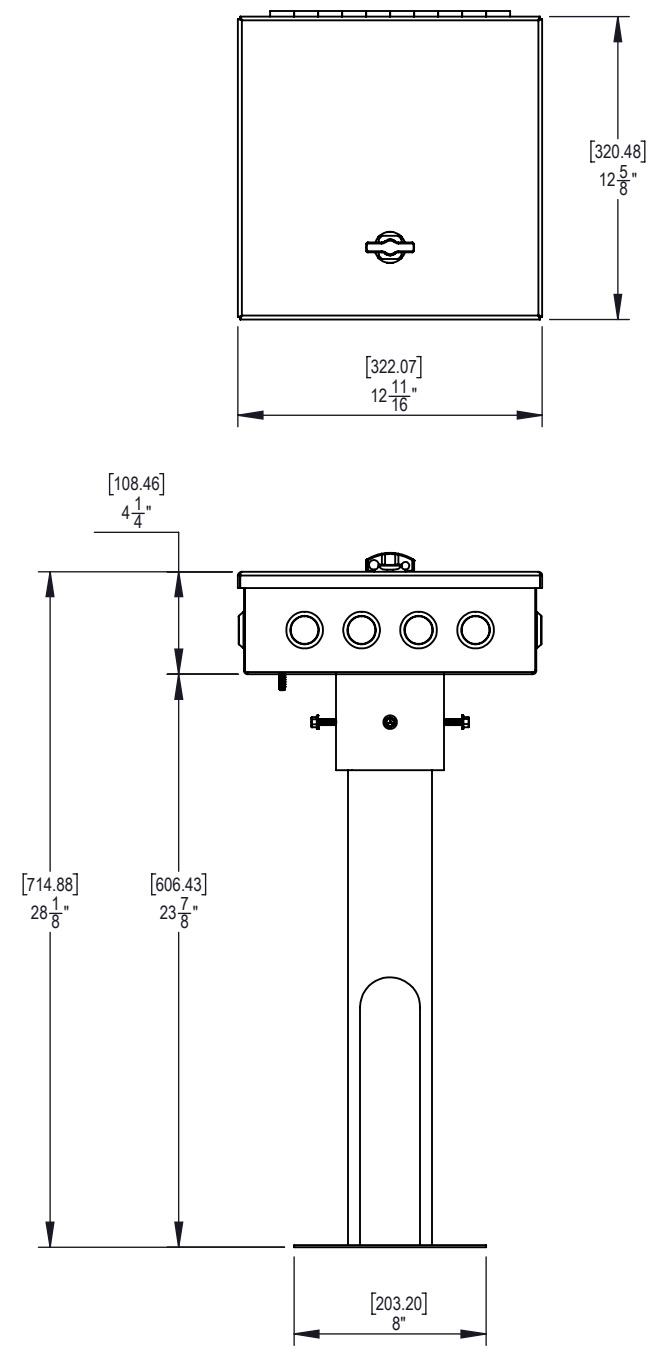

NOTE: DIMENSIONS IN [] ARE IN MILLIMETERS

MATERIAL ALUMINUM			PROJECT QUANTITY REQ. 1
MACHINING COMPLETE	FAB/WELD. COMPLETE	PAINTING COMPLETE	ASSEMBLY COMPLETE
ENG BY: AMS	INIT ISSUE:	SCALE: 1:6	PROJECT NO. P10519
DWN BY: AMS	LAST EDIT:	SHEET 1 OF 1	REV. 0
DRAWING NUMBER			MD11244.SALES



DIMENSIONAL TOLERANCES UNLESS OTHERWISE NOTED

FRACTIONAL = ±1/16"
 .X = ±.03
 .XX = ±.01
 .XXX = ±.005
 ANGULAR = ± 0°30'

APEC THERMAL
 PRODUCT DRAWING
 MECHANICAL DESIGN
 DRAWING NAME
JUNCTION BOX AND POST